

# User Manual

115.0 mm

**slamed**<sup>®</sup>  
instruments for sciences

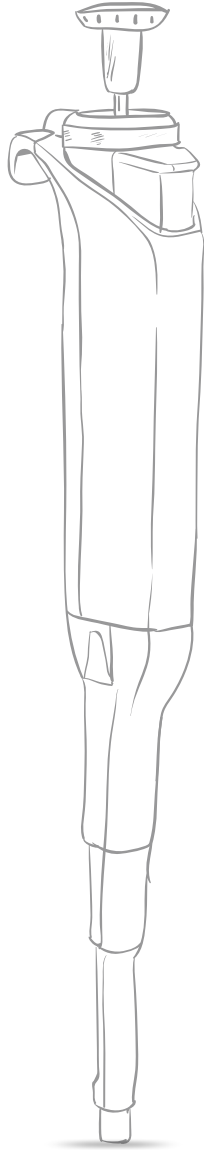

260.0 mm

Experience  
**EFFORTLESS PIPETTING**

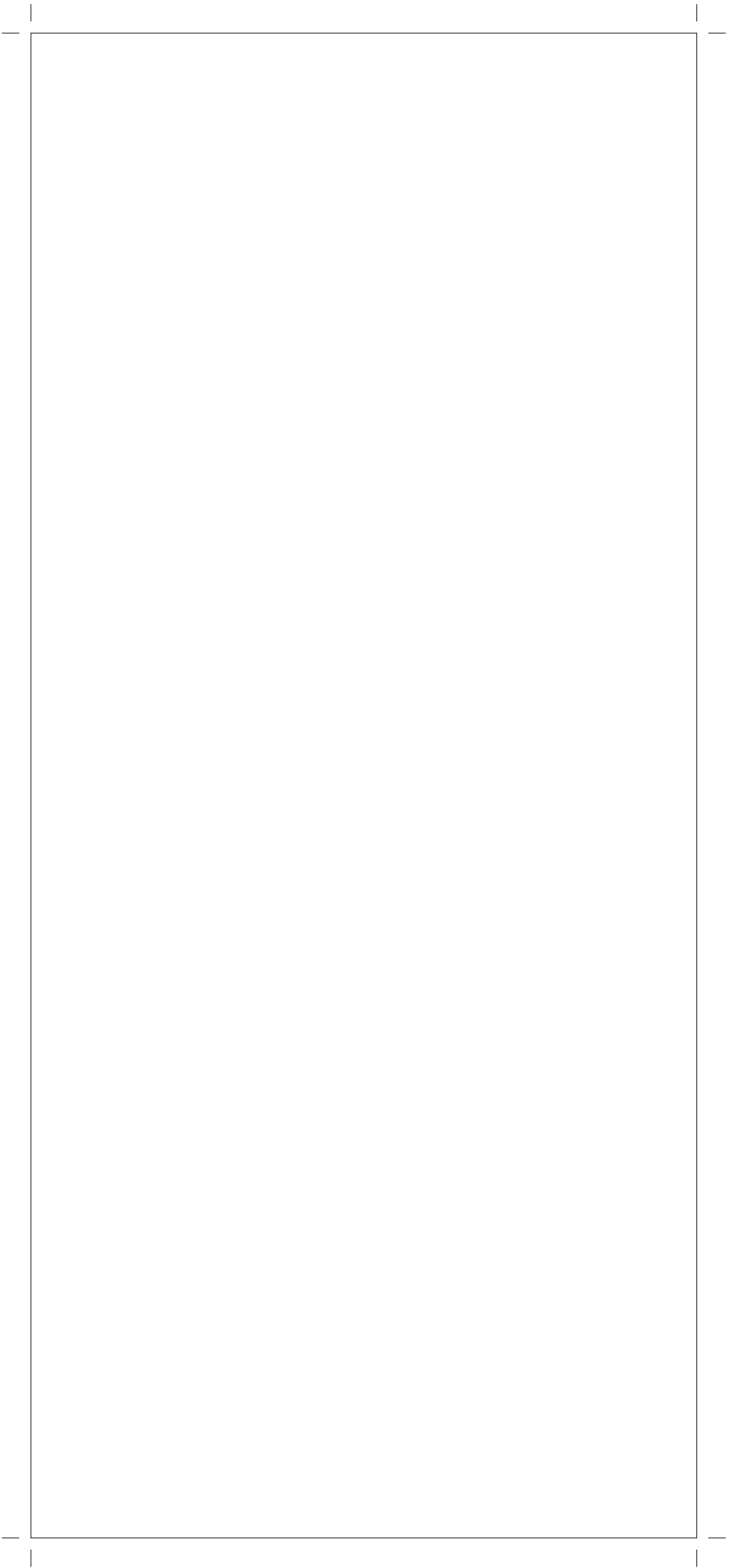

## TABLE OF CONTENTS

Sr. No.	Description	Page #
1	Introduction	1
1.1	Operating instructions for using this manual	1
1.2	Danger symbols and danger levels	1
2	Intended use	1
3	Package Contents	1
4	Product description	1
4.1	Variable volume pipette range	4
4.2	Fixed volume pipette range	4
4.3	Multi channel pipette range	5
4.4	Setting the volume	5
4.5	Volume indicator display example	6
4.6	Materials	6
5	Pipette operation	6
5.1	Pipetting guidelines	6
5.2	Setting the volume	7
5.3	Loading tips	8
5.4	Optimum immersion depths	8
5.5	Forward pipetting	8
5.6	Reverse pipetting	9
5.7	Aspiration of sample	9
5.8	Dispensing sample	9
5.9	Ejection of tips	9
6	Calibration and adjustment	9
6.1	Device requirements and test conditions	10
6.2	Calibration adjustment	10
6.3	Procedure to check calibration	10
6.3.1	Conversion of weight readings to volume	11
6.3.2	Calculation for in-accuracy (systematic error)	11
6.3.3	Calculation for imprecision (random error)	11
7	Maintenance and servicing	11
7.1	Disassembly	11
7.2	Disassembling the lower part	11
7.2.1	Disassembling the single channel pipette up to 1ml	12
7.2.2	Disassembling the single channel pipette: 5-10ml	12
7.3	Assembling the pipette	12
7.3.1	Assembling the single channel pipette up to 1ml	12
7.3.2	Assembling the single channel pipette: 5-10ml	12
7.4	Checking the function	13
7.5	Disassembling the multi channel pipette	13
7.5.1	Removing the lower assembly	13
7.5.2	Opening the lower assembly	13
7.5.3	Removing the channel	13
7.5.4	Fitting the channel	13
7.5.5	Assembling the lower assembly	13
7.5.6	Checking the function	13
7.6	List of spare parts - Single Channel Pipette	14
7.7	List of spare parts - Multichannel Pipette	19
7.8	Autoclaving	20
8	Trouble shooting guide	20

## 1. INTRODUCTION

You are now the proud owner of one of the most precise and lowest plunging force required mechanical pipette.

This manual will guide you on how to take care of your pipette and benefit the most from its advanced features as follows:



- Magnet assisted piston for precise results
- Innovative spring and seal design for one of the lowest plunge force requirement
- Corrosion resistant plastic tip ejector mechanism with unique shock absorbing design
- Volume lock
- Fully autoclavable
- Ergonomic design
- Easy in-house calibration
- Highly durable universal tip cone

### 1.1 OPERATING INSTRUCTIONS FOR USING THIS MANUAL

- Read this manual completely before using the device for the first time.
- This manual is part of the product. Please keep it in an easily accessible place.
- Enclose this manual when transferring the pipette to third parties.

### 1.2 DANGER SYMBOLS

The safety instructions in this manual have the following danger symbols and danger levels:

 Hazard point	 Material damage
--	---

## 2. INTENDED USE

This pipette is designed and manufactured for dispensing liquids in a measured way and to be used in combination with same brand tips for general laboratory use only.

This pipette is intended exclusively for indoor usage, and for operation by trained and skilled personnel.

## 3. PACKAGE CONTENTS

<i>Description</i>	<i>Quantity</i>
• Pipette	1
• Certificate of conformity including calibration certificate	1
• Warranty card	1
• Product manual	1
• Shelf-mounting stand	1
• Calibration tool	1
• Silicone grease	1
• Sample pack of tips	1

## 4. PRODUCT DESCRIPTION

This pipette works on air-displacement principle with the help of magnet assisted piston for aspirating and dispensing measured volume of liquid. It has to be used with disposable tips. The pipette tips are ejected with the help of ejector.



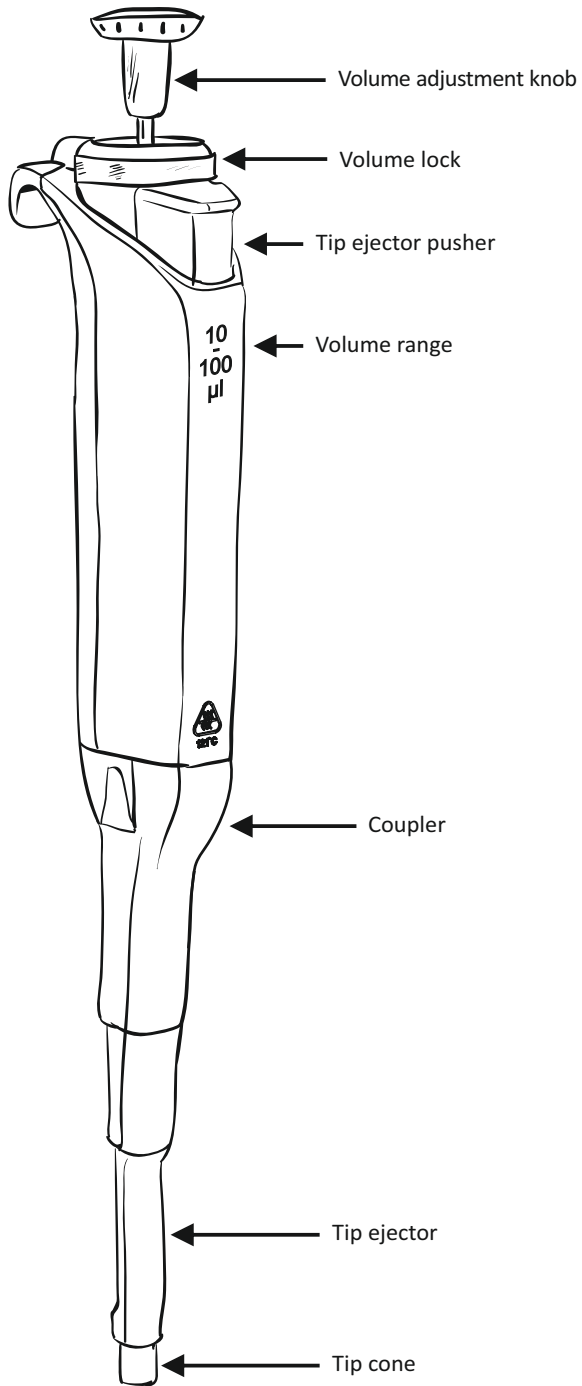



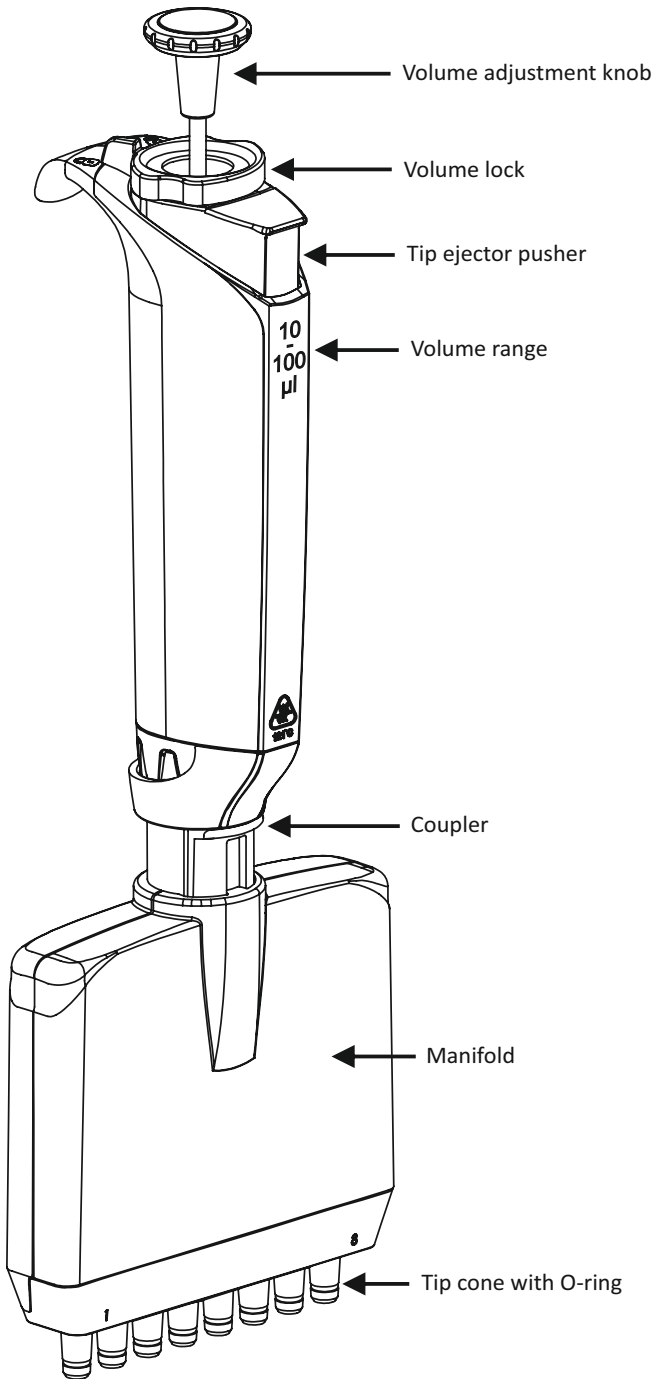

## SINGLE CHANNEL VARIABLE VOLUME



## MULTICHANNEL VARIABLE VOLUME









#### 4.1 VARIABLE VOLUME PIPETTE RANGE

CAT No.	Color Code	Volume Range [ $\mu\text{l}$ ]	Increments [ $\mu\text{l}$ ]	Test Volume [ $\mu\text{l}$ ]	Inaccuracy ( $\pm$ ) %	Imprecision ( $\pm$ ) %
4760001		0.1-2.5 $\mu\text{l}$	0.002	0.25	12	6
				1.25	2.5	1.5
				2.5	2.5	0.7
4760002		0.5-10 $\mu\text{l}$	0.02	1	2.5	1.5
				5	1.5	0.8
				10	1	0.4
4760003		2-20 $\mu\text{l}$	0.02	2	3	1.5
				10	1.2	0.6
				20	0.9	0.3
4760004		5-50 $\mu\text{l}$	0.1	5	2	2
				25	0.8	0.4
				50	0.6	0.3
4760005		10-100 $\mu\text{l}$	0.1	10	3	1
				50	1	0.3
				100	0.8	0.2
4760006		20-200 $\mu\text{l}$	0.2	20	2.5	0.7
				100	0.7	0.3
				200	0.6	0.2
4760007		100-1000 $\mu\text{l}$	1	100	3	0.6
				500	1	0.2
				1000	0.6	0.2
4760008		500-5000 $\mu\text{l}$	10	500	2.4	0.6
				2500	1.2	0.25
				5000	0.6	0.2
4760009		1000-10000 $\mu\text{l}$	20	1000	3	0.6
				5000	0.8	0.2
				10000	0.6	0.15

### 4.3 MULTI-CHANNEL PIPETTE RANGE

#### 8 Channels & 12 Channels

CAT No.	Color Code	Volume Range [ $\mu\text{l}$ ]	Increments [ $\mu\text{l}$ ]	Test Volume [ $\mu\text{l}$ ]	Inaccuracy ( $\pm$ ) %	Imprecision ( $\pm$ ) %
4760010 4760016		0.5-10 $\mu\text{l}$	0.02	1	8	5
				5	4	2
				10	2	1
4760011 4760017		2-20 $\mu\text{l}$	0.02	2	7	3
				10	3	2
				20	2	1.6
4760012 4760018		5-50 $\mu\text{l}$	0.1	5	3	2
				25	1.5	1
				50	1	0.7
4760013 4760019		10-100 $\mu\text{l}$	0.1	10	3	2
				50	1	0.8
				100	0.8	0.3
4760014 4760020		20-200 $\mu\text{l}$	0.2	20	5	1.4
				100	1	0.4
				200	0.7	0.25
4760015 4760021		30-300 $\mu\text{l}$	0.2	30	3	1
				150	1	0.5
				300	0.6	0.3

### 4.4 SETTING THE VOLUME

Delivery volume is clearly indicated in the volume display seen in the main body of the pipette.

In variable volume models, the bottom volume wheel includes a small increment scale for precise setpoint and delivery capabilities.

Some variable volume pipettes include one or two decimal places in the setpoint volume wheels. This is indicated by the use of a black horizontal line as seen in the following examples section.

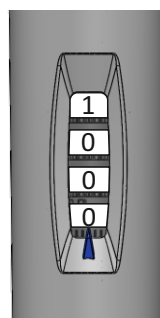



#### 4.5 VOLUME INDICATOR DISPLAY EXAMPLE

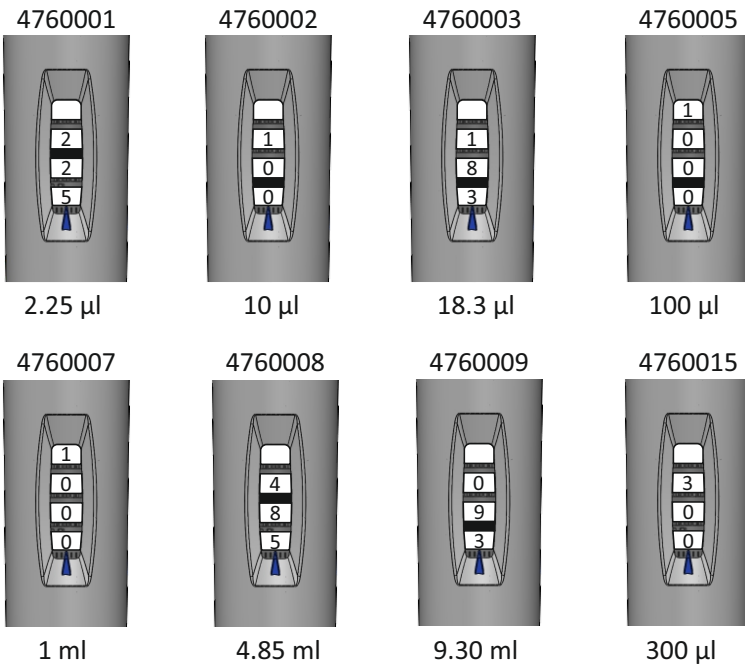

#### 4.6 MATERIALS



**NOTICE!** Aggressive substances may damage components, consumables and accessories.

- Check the chemical resistance before using organic solvents or aggressive chemicals.
- Only use liquids whose vapors do not attack the materials used.

### 5 PIPETTE OPERATION

#### 5.1 PIPETTING GUIDELINES

- Check the tip cone to make sure it is clean.
- While using the pipette make sure that operating plunger is handled slowly and smoothly.
- Ensure that the tip is firmly attached on the tip cone. Please check for foreign particles and remove if any, around the tip cone.
- Make sure that the temperature of tip, pipette and liquid are at equilibrium.
- While aspirating, hold the pipette in upright position and keep the tips at a constant depth below the surface of the liquid.
- Pre-rinse the pipette tip before aspirating the sample by filling and emptying the pipette tip five (5) times. This is important when dispensing samples that have a viscosity and density different from water and for volatile solvents.
- Do not pre-rinse the tip when pipetting samples with temperatures different from the current ambient temperature. Be sure to change the pipette tip after each pipetting.
- For the volatile solvents you should saturate the air-cushion of your pipette by aspirating and dispensing the solvent repeatedly before aspirating the sample.
- When pipetting liquids with temperature different to the ambient temperature, pre-rinse tips tip several times before use.

- After pipetting acids or other corrosive liquids that emit vapors, remove the tip-cone and rinse the piston, O-ring and seal with distilled water.
- Do not pipette liquids having temperatures above 70°C. (Not recommendable)
- Make sure that liquids never enter the tip-cone. To prevent this:
  - Avoid laying the pipette horizontally when tip is filled with sample. As liquid may enter in and contaminate the sample during next pipetting cycle.
  - When there is liquid in the tip, press and release the volume adjustment knob slowly and smoothly.
  - Never turn the pipette upside down.
- Always store the pipette without tip on a shelf mounting stand supplied with or a pipette carousel stand.
- Highly recommended to calibrate the pipette once in every 3-6 months (depending on the sensitivity of usage) for better performance. The calibration must be carried by gravimetric method in accordance of DIN ISO 8655-6.

## 5.2 SETTING THE VOLUME

- To set the volume turn the volume lock lever to the “unlock” position so that the volume can be adjusted to the desired setpoint within the permitted volume range. Refer following images

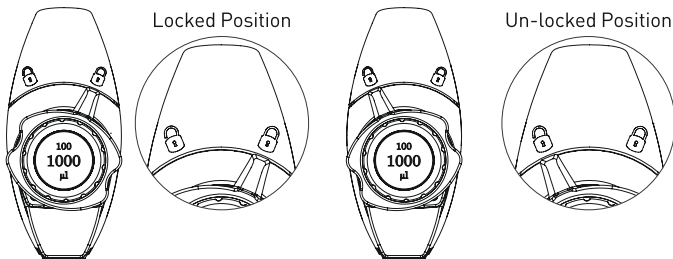

- To decrease the volume, turn the volume setting knob clockwise.
- To increase the volume, turn the volume setting knob counterclockwise.
- Do make sure that the desired delivery volume is set in-line with pointer.
- Turn the volume lock to “lock” the volume setting, preventing any accidental change in the volume during pipetting.

For this pipette the delivery volume of liquid is set using the digital display. A pointer is used to set exact or intermediate volumes using the scale on the last wheel of digital display (refer point # 4.6)

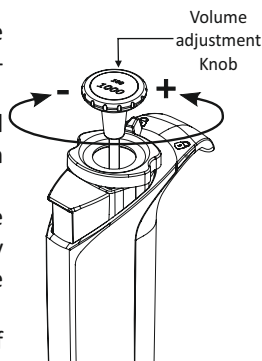

**⚠** The Locking mechanism ensures that the volume adjustment knob remains at the setpoint while aspirating or dispensing sample liquids. Any effort to rotate the volume adjustment knob with the locking mechanism engaged will damage the locking mechanism and void the warranty.

⚠ Setting the volume beyond the allowable volume range is not permitted. Using excessive force to turn the volume adjustment knob outside the permitted range will jam the mechanism, damage the pipette and void the warranty.

### 5.3 LOADING TIPS

Using correct pipette tip according to the pipette volume range is recommended. It is necessary to check that the tip cone is clean before fitting a tip. Press the tip on the cone of the pipette firmly to ensure an air tight seal. Always ensure that the tip is correctly sealed to avoid any leakage while pipetting.

### 5.4 OPTIMUM IMMERSION DEPTHS

<i>Volume</i>	<i>Immersion depth</i>
0.1 $\mu$ l - 1 $\mu$ l	1 mm
1 $\mu$ l - 100 $\mu$ l	2 - 3 mm
100 $\mu$ l - 1000 $\mu$ l	2 - 4 mm
1ml - 10ml	3 - 5 mm

Tip immersion depth is critical and should not be exceeded, as then the volume measured may be inaccurate, possibly out of specification. The tip angle is also important; the pipette should always be used in a position within 20° angle of vertical. See figure below.

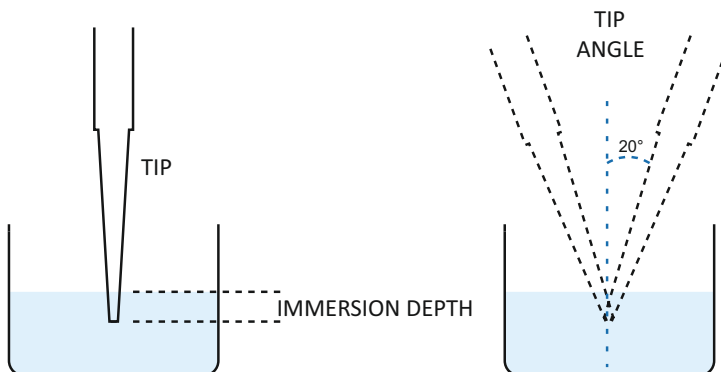

### 5.5 FORWARD PIPETTING

1. Press the operating knob until the first stop.
2. Dip the tip under the surface of the liquid in the reservoir and slowly release the operating knob. Withdraw the tip from the liquid, touching it against the edge of the reservoir to remove excess liquid.
3. Dispense the liquid by gently pressing the operating knob to the first stop. After a delay of about one second, continue to press the operating knob all the way to the second stop. This action will empty the tip.
4. Release the operating button to the ready position. Change the tip and continue pipetting.

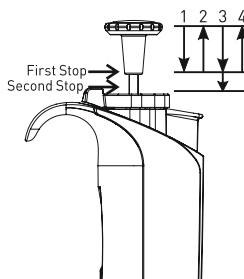

## 5.6 REVERSE PIPETTING

The reverse pipetting technique is suitable for dispensing liquids that have high viscosity or a tendency to foam easily. This technique is also recommended for dispensing very small volumes.

1. Press the operating knob until the second stop.
2. Dip the tip under the surface of the liquid in the reservoir and slowly release the operating knob. This action will fill the tip. Withdraw the tip from the liquid touching it against the edge of the reservoir to remove excess liquid.
3. Dispense the preset volume of liquid by gently pressing the operating knob to the first stop. Hold the operating knob at the first stop. Some liquid will remain in the tip and it should not be dispensed.
4. The remaining liquid should either be discarded with the tip or should be dispensed back into the reagent reservoir.

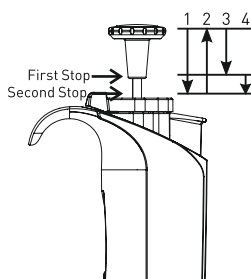

## 5.7 ASPIRATION OF SAMPLE

- Hold the pipette vertically; press volume adjustment knob to its first stop. Place the tip into the sample at proper depth (refer point # 5.4) and relax your thumb pressure on the plunger. The light piston spring will move the piston upward, aspirating sample.
- Pause for about 1 second (longer for macro-volume pipettes) to ensure that the full volume of sample is drawn into the tip.
- Withdraw the tip from the sample. If any liquid remains on the outer surface of the tip, touch it off carefully onto a lint-free tissue, taking care not to touch the tip orifice.

## 5.8 DISPENSING SAMPLE

1. Place the pipette tip against the reservoir wall to avoid any bubbles or splashing of sample out of the reservoir.
2. Press the plunger slowly past the first stroke and second stroke for complete blow out of liquid sample. For viscous samples, it is recommended to wait for few seconds till the fluid passes out to the reservoir.
3. Pull the tip gently along the wall of the reservoir and release the plunger slowly.
4. Discard the tip to avoid any carry over sample or cross contamination. It is highly recommended to change the tip and then repeat the pipetting cycle.

## 5.9 EJECTION OF TIPS

The tip ejector needs to be pressed downwards firmly with the thumb to ensure proper tip ejection. Once the process is complete, make sure the tips are disposed of into a suitable waste container.

## 6 CALIBRATION AND ADJUSTMENT

All pipettes are been quality tested according to ISO8655-6. The quality control process according to ISO 8655-6 involves gravimetric testing of each pipette with double distilled water.

All pipettes are calibrated in ISO/IEC 17025 accredited laboratory. Each Pipette is calibrated, inspected and validated by qualified technicians according to defined quality system.

## 6.1 DEVICE REQUIREMENTS AND TEST CONDITIONS

An analytical balance must be used. The balance selection depends upon selected model of the pipette and sensitivity of balance reading.

Test liquid: Water, distilled or de-ionized, grade 3 water conforming ISO3696 Calibration should be carried out in a draft-free room at a constant ( $\pm 0.5^{\circ}\text{C}$ ) temperature of water, pipette and air between  $15^{\circ}\text{C}$  to  $30^{\circ}\text{C}$ .

The relative humidity must be above 50% especially with volumes under  $50\ \mu\text{l}$ , the air humidity should be as high as possible to reduce the effect of evaporation loss.

Special accessories for analytical balance, such as the evaporation trap are recommended for the calibration of volumes under  $50\ \mu\text{l}$ .

## 6.2 CALIBRATION ADJUSTMENT

1. Calibration adjustment is done with the calibration tool provided along with pipette.
2. Rotate the volume locking lever to the "lock" position so the volume setting mechanism is locked and able to turn the calibration screw.

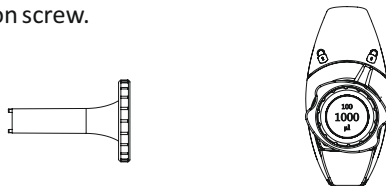

3. Remove volume adjustment knob by pulling it upwards.

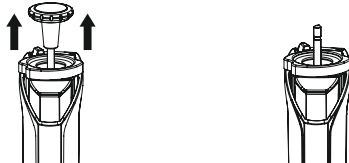

4. Place the calibration tool into the calibration grooves.



5. Rotate the calibration tool counter clockwise to increase and clockwise to decrease the volume.
6. After adjustment, check the calibration according to the instruction in point number 6.3
7. Once within permissible error range, remove the calibration tool from pipette and place volume adjustment knob in its original position.

 Depending upon use, we recommend checking of calibration every six months. However this can be adjusted to individual requirements.

## 6.3 PROCEDURE TO CHECK CALIBRATION

The pipette is checked at maximum volume, at 50 % of maximum volume and at minimum or 10% of maximum volume, whichever is higher.

- A new tip is first pre-wetted 3-5 times and a series of ten pipetting is done at each volume.
- Use of forward pipetting technique is recommended.

- Calculate the inaccuracy and imprecision for all three volumes as per EN ISO 8655-6 standards on the basis of the following calculation

### 6.3.1 CONVERSION OF WEIGHT READINGS TO VOLUME

$$\text{Mean Volume } \bar{V} = \bar{X} \cdot Z$$

$$\text{Mean Weight } \bar{X} = \frac{\sum X_i}{n}$$

$X_i$  = Balance Reading

$n$  = number of reading

$Z$  = Conversion factor

[example  $Z=1.0040 \mu\text{l}/\text{mg}$  at  $25^\circ\text{C}$  and  $1013 \text{ hPa}$ ]

### 6.3.2 CALCULATION FOR IN-ACCURACY (SYSTEMATIC ERROR)

$$A\% = \frac{\bar{V} - V_0}{V_0} \cdot 100$$

$\bar{V}$  = Mean Value

$V_0$  = Particular volume at which readings are taken

### 6.3.3 CALCULATION FOR IMPRECISION (RANDOM ERROR)

$$S = \sqrt{\frac{\sum_{i=1}^n (V_i - \bar{V})^2}{n - 1}}$$

$S$  = Standard Deviation

$\bar{V}$  = Mean Value

$n$  = number of readings

$$CV\% = \frac{100 \cdot S}{\bar{V}}$$

Compare the results to the limits in the earlier tables (Page# 4, 5)

## 7 MAINTENANCE & SERVICING

When the pipette is not in use it should be stored in an upright position. The pipette should be inspected prior to use each day for any dust or contamination on outside surfaces. Special attention should be given to the tip cone. No solvent other than isopropanol should be used to clean the pipette. If the pipette is used daily, an internal parts inspection should be performed every three (3) months.

### 7.1 DISASSEMBLY

The servicing procedure starts with the disassembly of the pipette. Please refer to the spare parts lists for better understanding of the components.

### 7.2 DISASSEMBLING THE LOWER PART

1. Press tip ejector pusher completely down and hold.
2. Pull down the tip ejector and release the tip ejector pusher.

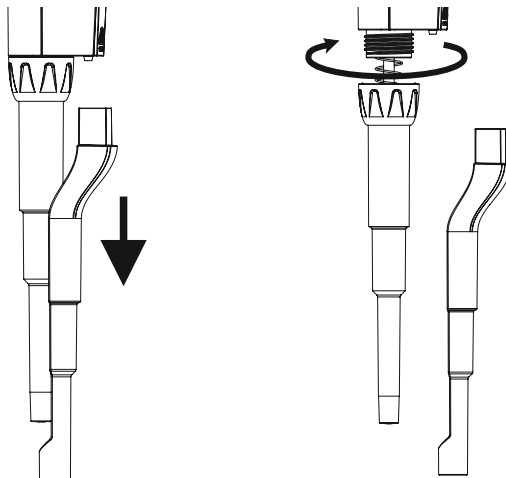

### 7.2.1 DISASSEMBLING THE SINGLE-CHANNEL PIPETTE UP TO 1ml

1. Unscrew the coupler and remove tip cone.
  2. Remove the lower part and pull out the piston and other parts from tip cone.
- Remember to keep all parts in order for reassembly.
  - Clean the piston, the piston spring, seal and the o-ring with isopropanol and lint free tissue. Allow them to dry.
  - Check the tip cone for foreign articles and remove, if any. Grease the cleaned parts with the approved lubricant provided with each pipette.

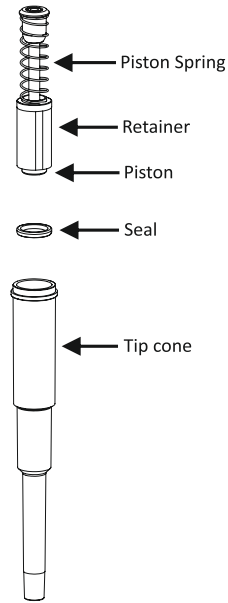

### 7.2.2 DISASSEMBLING THE SINGLE-CHANNEL PIPETTE: 5 - 10ml

1. As per earlier process remove the ejector by pulling it after pressing the tip ejector pusher completely down.
  2. Unscrew the coupler to tip cone and pull out the piston and other parts from tip cone.
- Remember to keep all parts in order for reassembly.
  - Clean the piston, the piston spring, seal and the o-ring with isopropanol and lint free tissue. Allow them to dry.
  - Check the tip cone for foreign particles and remove, if any. Grease the cleaned parts with the approved lubricant provided with each pipette.

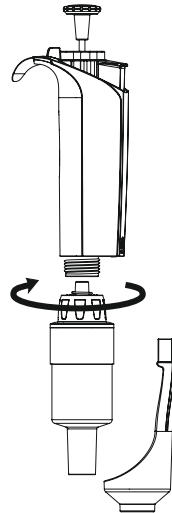

## 7.3 ASSEMBLING THE PIPETTE

### 7.3.1 ASSEMBLING THE SINGLE-CHANNEL PIPETTE UP TO 1ml

1. Carefully insert the piston into the tip cone.
2. Press on piston from above and check for free movement. The piston must be able to move freely without resistance.
3. Reconnect the tip cone to the main body by screwing into the threaded section.
4. Reinstall the tip ejection collar.

### 7.3.2 ASSEMBLING THE SINGLE-CHANNEL PIPETTE: 5 - 10ml

1. Insert the seal on position.
2. Keep retainer on piston and spring. Press the spring to fit with piston.
3. Carefully insert the piston into the tip cone.
4. Press on piston from above and check for free movement. The piston must be able to move freely without resistance.
5. The coupler screw to tip cone and screw with body.
6. Fit the ejector collar.

#### 7.4 CHECKING THE FUNCTION

It is to ensure that the pipette has been assembled correctly.

- Carry out a gravimetric test for the systematic and random error.

#### 7.5 DISASSEMBLING THE MULTI-CHANNEL PIPETTE

##### 7.5.1 REMOVING THE LOWER ASSEMBLY

1. Press the tip ejector pusher completely and hold it while unscrewing the coupler from upper part of pipette.
2. Remove the lower assembly.

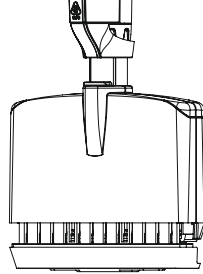

##### 7.5.2 OPENING THE LOWER ASSEMBLY

1. Unscrew the two small screws from back side and safely keep it. (Refer image -1)
2. Press and push up from side to open the front cover. (Refer image -2)

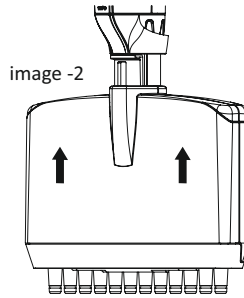
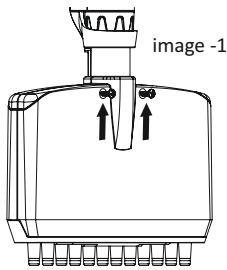

##### 7.5.3 REMOVING THE CHANNEL

1. Slightly push the spring and pull up tip cone to remove it from the lower rail. (image -3)
2. Carefully release the piston from the upper rail and move upward to remove it. (image -4)

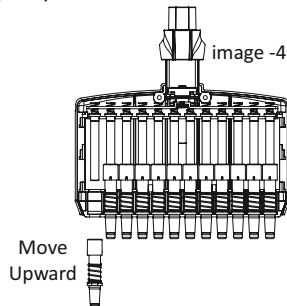
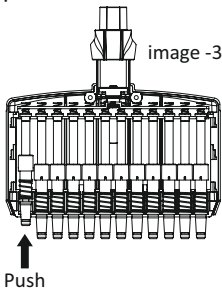

##### 7.5.4 FITTING THE CHANNEL

1. Insert the spring with cylinder into the centre rail.
2. Insert the piston into the cylinder and fit into upper rail.
3. Compress the spring with the cylinder and insert the cylinder into the lower rail.

##### 7.5.5 ASSEMBLING THE LOWER ASSEMBLY

1. Attach the front cover and screw it.
2. Press the pusher completely and hold it while screwing the coupler nut to body.

##### 7.5.6 CHECKING THE FUNCTION

It is to ensure that the pipette has been assembled correctly.

- Carry out a gravimetric test for the systematic and random error.





## 7.6 LIST OF SPARE PARTS - SINGLE CHANNEL PIPETTE

### Group 1

Variable volume 0.1-2.5 $\mu$ l

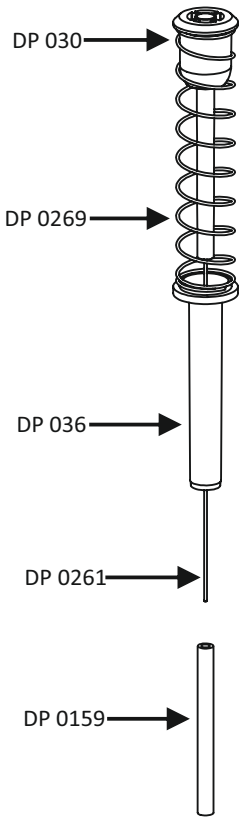
Fix volume 2.5 $\mu$ l



SP 0160 → 

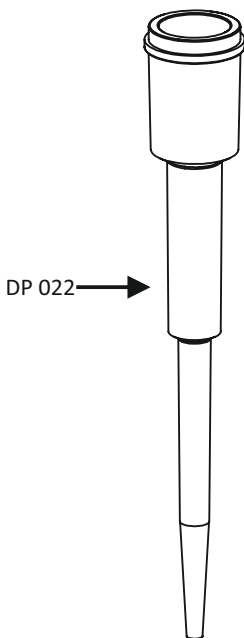



DP 022 →

### Group 2

Variable volume 0.5-10 $\mu$ l

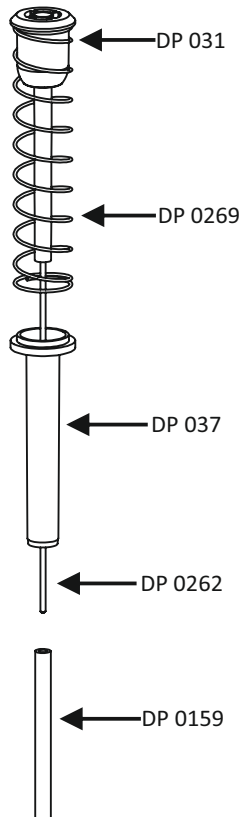
Fix volume 10 $\mu$ l



 ← SP 0158

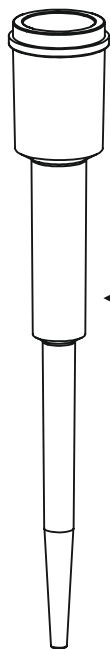

← DP 022

**Group 3**

Variable volume 2-20 $\mu$ l

Fix volume 20 $\mu$ l

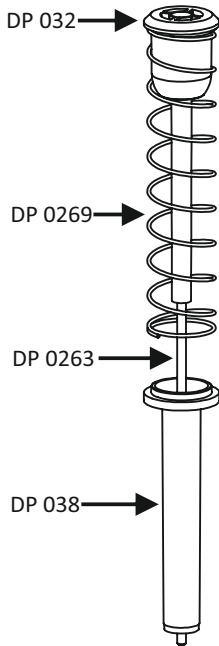

SP 0152: O-ring

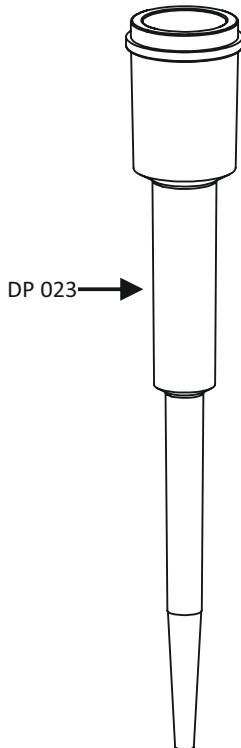

**Group 4**

Variable volume 5-50 $\mu$ l

Fix volume 25 $\mu$ l  
50 $\mu$ l

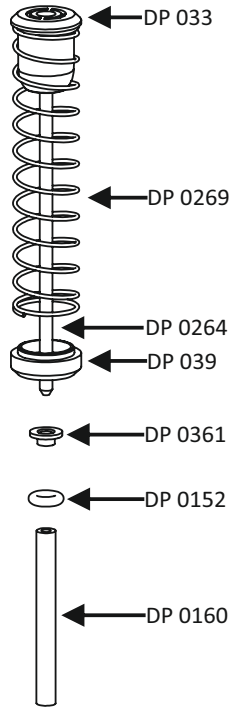

DP 0160



**Group 5**

Variable volume 10-100µl

Fix volume 100µl

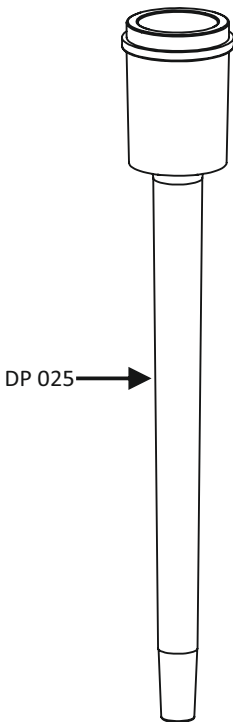
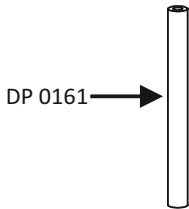
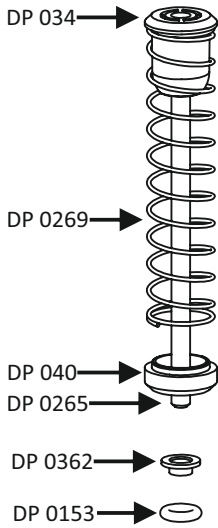

**Group 6**

Variable volume 20-200µl

Fix volume 200µl

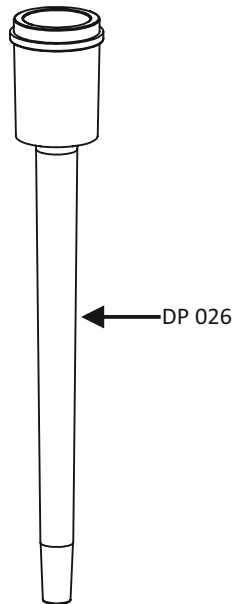
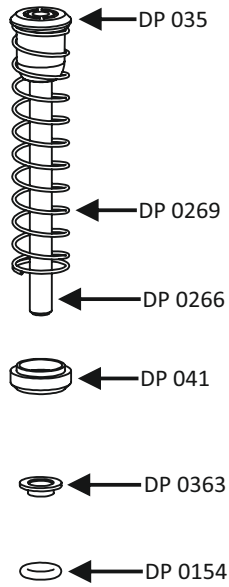

**Group 7**

Variable volume 100 - 1000 $\mu$ l

Fix volume 250 $\mu$ l

500 $\mu$ l

1000 $\mu$ l

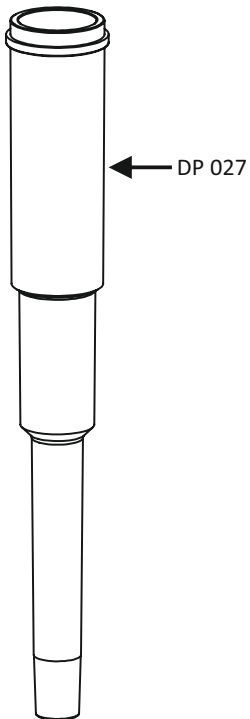
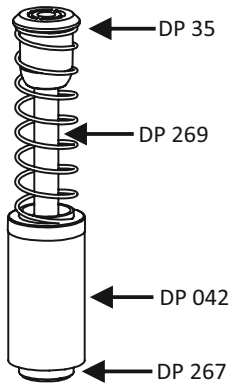

**Group 8**

Variable volume 0.5-5ml

Fix volume 2ml  
5ml

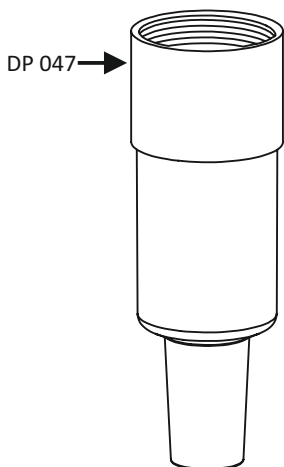
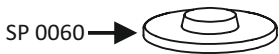
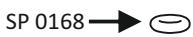
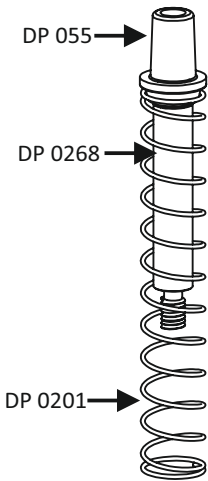
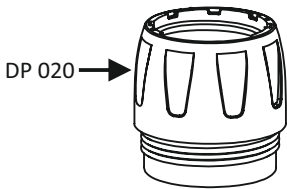

**Group 9**

Variable volume 1-10ml

Fix volume 10ml

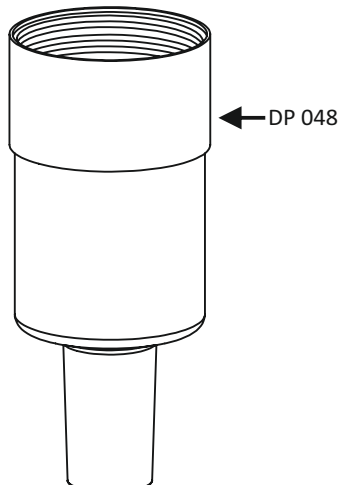
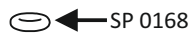
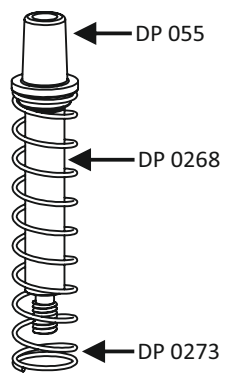
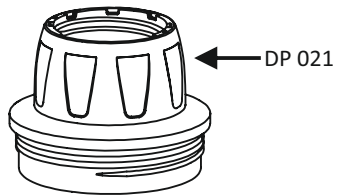

## 7.7 LIST OF SPARE PARTS - MULTICHANNEL PIPETTE

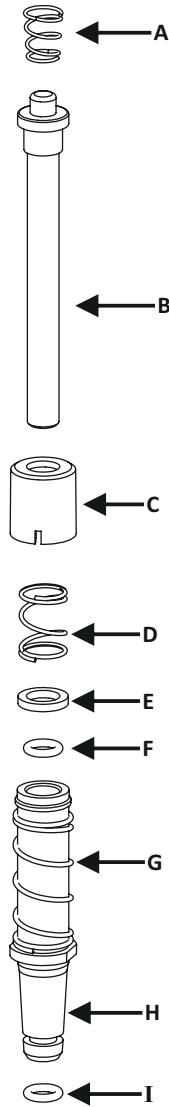

Part	Cat#					
	4760010 4760016 (0.5-10µl)	4760011 4760017 (2-20µl)	4760012 4760018 (5-50µl)	4760013 4760019 (10-100µl)	4760014 4760020 (20-200µl)	4760015 4760021 (30-300µl)
A	CE 0200	CE 0200	CE 0200	CE 0200	CE 0200	CE 0200
B	DPM 140	DPM 141	DPM 136	DPM 137	DPM 138	DPM 139
C	DPM 123	DPM 123	DPM 124	DPM 125	DPM 126	DPM 127
D	DPM 276	DPM 276	DPM 281	DPM 277	DPM 281	DPM 281
E	DPM 364	DPM 364	DPM 365	DPM 366	DPM 367	DPM 368
F	SPM 152	SPM 154	DPM 166	SPM 155	DPM 171	DPM 168
G	DPM 278	DPM 278	DPM 278	DPM 278	DPM 278	DPM 278
H	DPM 128	DPM 129	DPM 130	DPM 131	DPM 132	DPM 133
I	---	---	SP0156	SP0156	SP0156	SP0156

## 7.8 AUTOCLAVING

This pipette is completely autoclavable at 1 bar pressure and 121°C temperature for 20 minutes exposure time.

### AUTOCLAVING INSTRUCTIONS

- Keep digital counter in unlock position.
- Do not dis-assemble the pipette for autoclaving.
- After autoclaving, allow the pipette to completely cool and fully dry for a minimum of four (4) hours.

If the pipette is autoclaved frequently, the piston and springs should be greased with supplied lubricant along with each pipette to maintain smooth movement.

## 8 TROUBLE SHOOTING GUIDE

Problem area	Possible Cause	Solution
Pipette is leaking	Worn o-ring or seal	Replace worn parts
	Foreign particles between tip and tip cone	Clean tip cone, attach new tip
	Foreign particles between piston and seal	Clean seal and piston
Pipette does not aspirate the solution	Worn o-ring or seal	Replace worn parts
	Tip cone is loose	Tighten tip cone
	Piston is damaged (Chemically or mechanically)	Return pipette to authorised distributor
	Damaged tip cone	Replace the tip cone
Pipette is inaccurate	Improper assembly	See "Maintenance" section
	Tip cone is loose	Tighten tip cone
	Tip incorrectly attached	Attach firmly
	Calibration altered	Recalibrate according to instructions
Inaccurate dispensing with certain liquids	Calibration not suitable for particular liquid	Recalibrate with the liquid in question

**slamed**<sup>®</sup>  
instruments for sciences